

LOC		DIST		REVISIONS					
ES		00		P	LTN	DESCRIPTION	DATE	DWN	APVD
E3						ADDED THE DASH NUMBER -15	10AUG2012	ML	SZ
E4						REVISED	13DEC2012	CZ	SZ
E6						ADD NEW DASH NO.	20JAN2014	AL	SZ

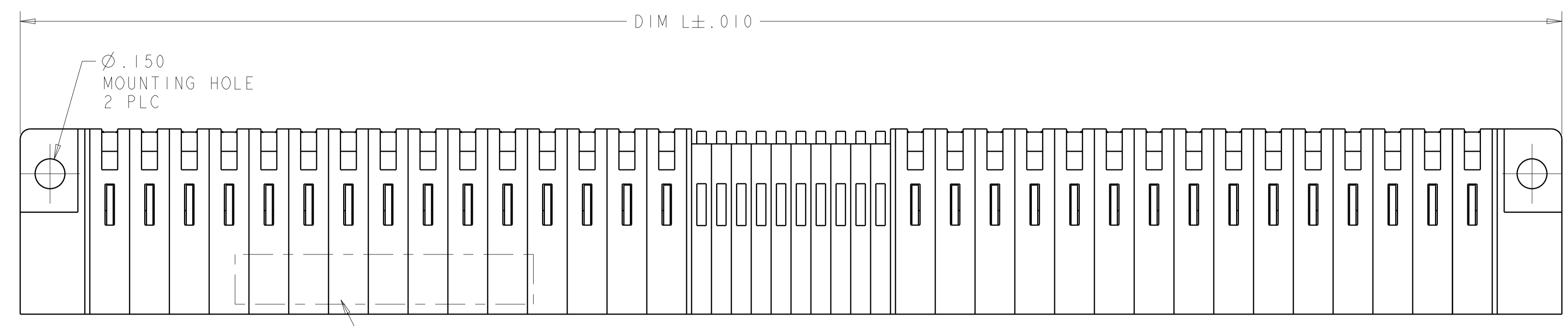

- △ "AMP", PART NUMBER, AND DATECODE TO BE MARKED IN AREA SHOWN. PARTS UNDER 2.00 LONG MAY BE MARKED ON BOTH SIDES.
- △ MATERIAL: HOUSING - GLASS FILLED HIGH TEMP THERMO PLASTIC, UL94 V-0
 POWER CONTACT - HIGH CONDUCTIVITY COPPER ALLOY
 SIGNAL CONTACT - HIGH CONDUCTIVITY COPPER ALLOY
- △ CONTACT PLATING: NOBEL METAL PLATED ON CONTACT FUNCTIONAL AREA OF POWER OR SIGNAL CONTACTS,
- △ MECHANICAL CONNECTOR KEEP OUT ZONE.
- △ DATUM AND BASIC DIMENSIONS ESTABLISHED BY CUSTOMER.
- △ PCB - HOLE DIAMETERS ARE FINISHED HOLE SIZE.
- △ PCB - .0453±.0010 DRILLED HOLES PLATED WITH .0003 MIN Sn OVER .001 TO .003 Cu PLATING TO ACHIEVE A .040 DIA HOLE.
- △ NOT RELEASED FOR PRODUCTION.

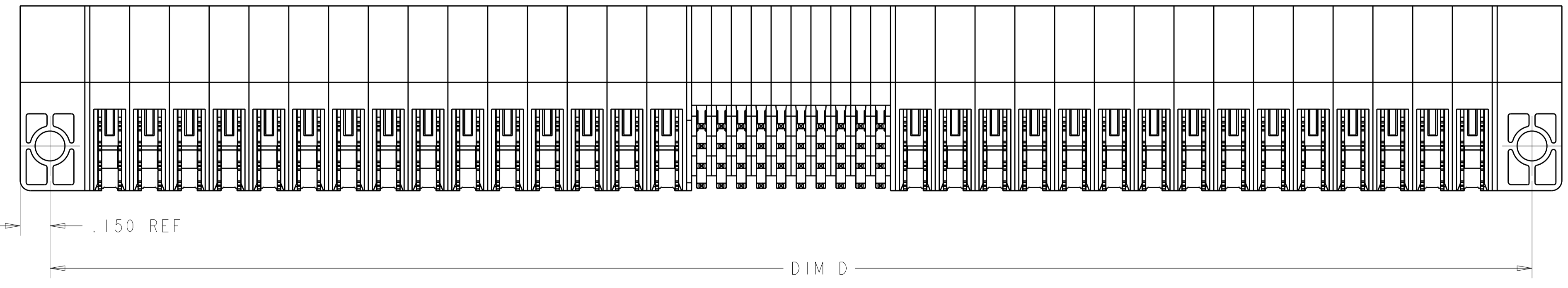
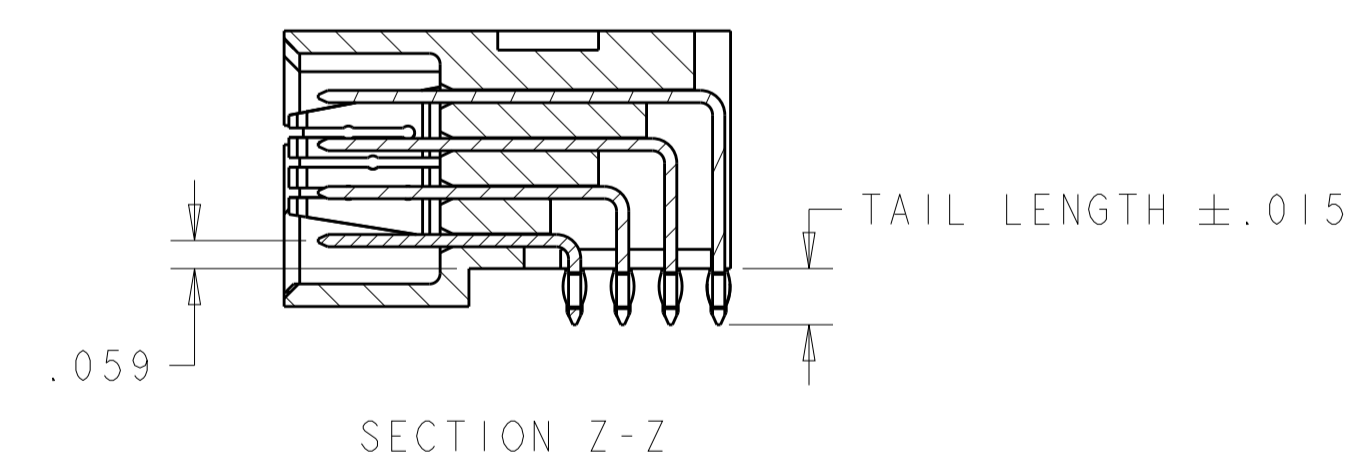
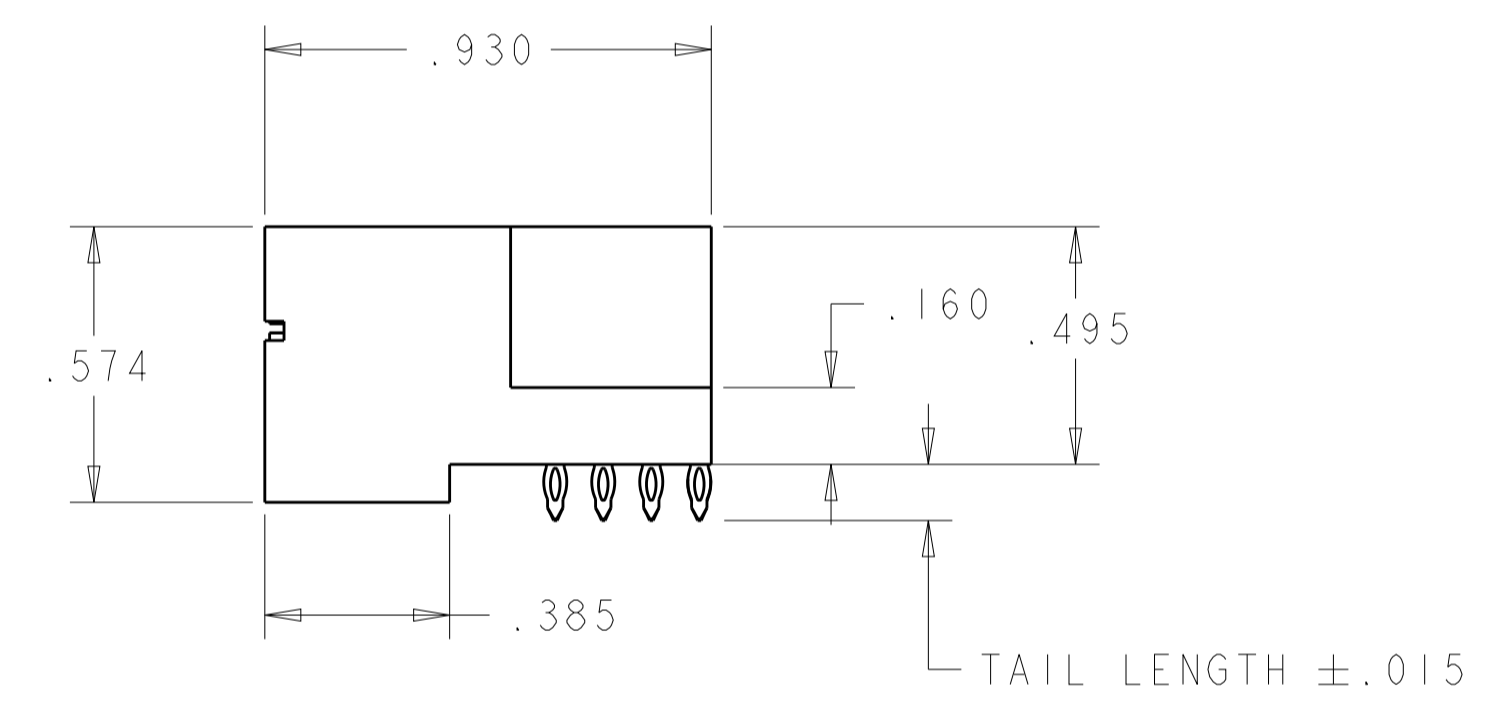
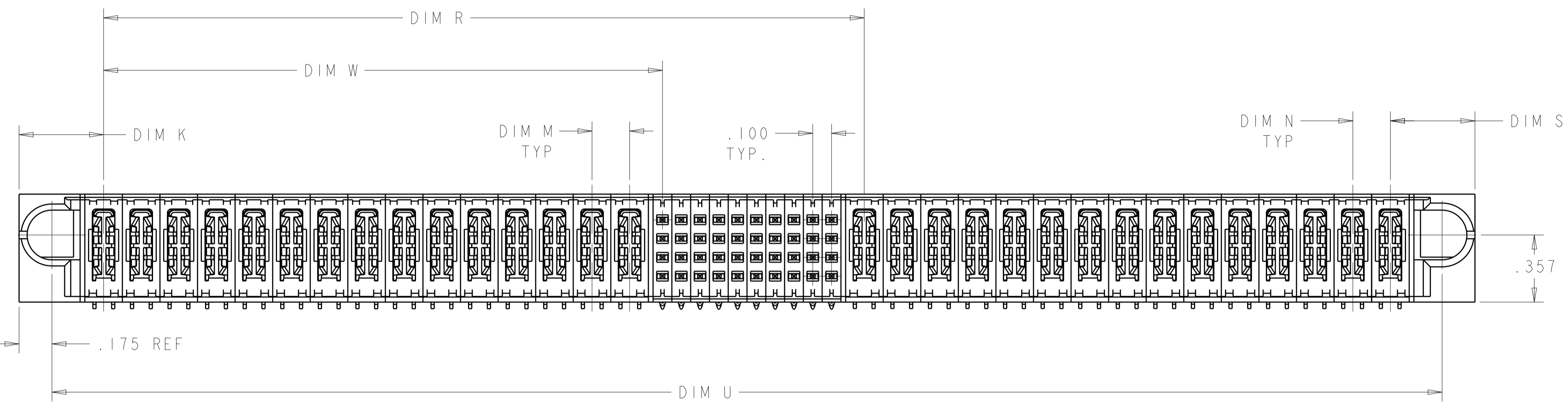

THIS DRAWING IS A CONTROLLED DOCUMENT.		DWN T. ZHANG 17MAY2006	TE Connectivity
DIMENSIONS: INCHES		CHK G. ZHANG 17MAY2006	
TOLERANCES UNLESS OTHERWISE SPECIFIED:		APVD S. ZHAO 17MAY2006	NAME RIGHT ANGLE HEADER ASSEMBLY W/ GUIDE, PRESS FIT MULTI-BEAM XL
0 PLC ±. 1 PLC ±.01 2 PLC ±.01 3 PLC ±.005 4 PLC ±.0020 ANGLES ±.2°		PRODUCT SPEC 108-1973	SIZE A100779
MATERIAL		APPLICATION SPEC 114-13038	CAGE CODE C=6450520
FINISH		WEIGHT	RESTRICTED TO
CUSTOMER DRAWING		SCALE 4:1	SHEET 1 OF 7
		REV E6	

THIS DRAWING IS UNPUBLISHED. RELEASED FOR PUBLICATION 20
 © COPYRIGHT 20 TE CONNECTIVITY ALL RIGHTS RESERVED.

LOC	DIST	REVISIONS					
		P	LTN	DESCRIPTION	DATE	DWN	APVD
ES	00	-		SEE SHEET 1	-	-	-

.300	.250	3.300	.450	.450	3.25	.925	1.200	3.6	4P+8S+6P	1-6450520-8
.300	.250	3.200	.450	.450	3.15	.925	1.400	3.5	4P+16S+5P	1-6450520-7
.250	-	2.950	.450	.450	2.900	.925	1.600	3.250	4P+24S+4P	1-6450520-6
-	.300	1.700	-	.475	1.650	.850	-	2.000	3ACP+16S	1-6450520-5
-	-	1.575	-	.400	1.525	-	-	1.875	48S	1-6450520-4
-	-	1.975	-	.400	1.925	-	-	2.275	64S	1-6450520-3
.250	.250	5.950	.450	.450	5.900	2.425	3.100	6.250	10P+24S+10P	1-6450520-2
-	-	1.350	.450	.450	1.300	.225	0.750	1.650	1P+16S+1P	1-6450520-1
.250	.250	2.150	.450	.450	2.100	.725	1.050	2.450	3P+8S+3P	6450520-9
-	-	1.150	.450	.450	1.100	.225	.550	1.450	1P+8S+1P	6450520-8
.200	.200	-	-	.450	-	1.175	2.150	3.970	6HDP+36S+7HDP	6450520-7
.200	.200	-	-	.450	-	1.175	2.150	3.770	6P+36S+6P	6450520-6
.200	.200	-	-	.450	-	2.975	4.050	7.470	15P+40S+15P	6450520-5
.200	.200	-	.450	-	-	2.975	4.050	7.470	15P+40S+15P	6450520-4
N	M	D	S	K	U	W	R	L	DESCRIPTION	PART NUMBER

E6

THIS DRAWING IS A CONTROLLED DOCUMENT.		DWN T. ZHANG 17MAY2006	 TE Connectivity NAME RIGHT ANGLE HEADER ASSEMBLY W/ GUIDE, PRESS FIT MULTI-BEAM XL
DIMENSIONS: INCHES		CHK G. ZHANG 17MAY2006	
TOLERANCES UNLESS OTHERWISE SPECIFIED:		APVD S. ZHAO 17MAY2006	
0 PLC ±. 1 PLC ±.01 2 PLC ±.01 3 PLC ±.005 4 PLC ±.0020 ANGLES ±.020		PRODUCT SPEC 108-1973 APPLICATION SPEC 114-13038	
MATERIAL	FINISH	WEIGHT	SIZE CAGE CODE DRAWING NO A100779C=6450520 RESTRICTED TO
CUSTOMER DRAWING		SCALE 4:1	SHEET 2 OF 7 REV E6

LOC	DIST	REVISONS				
ES	00	REV	DATE	BY	APPV	
		1	-	-	-	
		2	-	-	-	

PART NUMBER	ROWS	POWER															SIGNAL										POWER																		
		P1	P2	P3	P4	P5	P6	P7	P8	P9	P10	P11	P12	P13	P14	P15	1	2	3	4	5	6	7	8	9	10	P16	P17	P18	P19	P20	P21	P22	P23	P24	P25	P26	P27	P28	P29	P30				
6450520-4	D C B A	PT	PT	PT	PT	PT	PT	PT	PT	PT	PT	PT	PT	PT	PT	Z5	Z5	Z5	Z5	Z5	Z5	Z5	Z5	Z5	Z5	PT	PT	PT	PT	PT	PT	PT	PT	PT	PT	PT	PT	PT	PT	PT	PT	PT	PT	PT	PT
		15P + 40S + 15P																																											

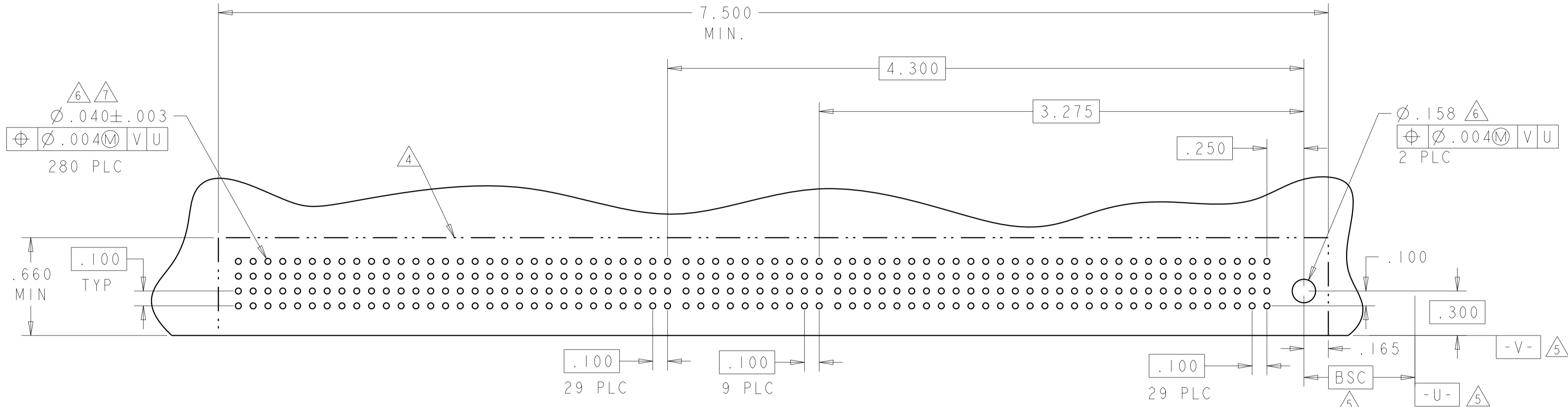

PART NUMBER	ROWS	POWER															SIGNAL										POWER																			
		P1	P2	P3	P4	P5	P6	P7	P8	P9	P10	P11	P12	P13	P14	P15	1	2	3	4	5	6	7	8	9	10	P16	P17	P18	P19	P20	P21	P22	P23	P24	P25	P26	P27	P28	P29	P30					
6450520-5	D C B A	PT	PT	PT	PT	PT	PT	PT	PT	PT	PT	PT	PT	PT	PT	Z5	Z5	Z5	Z5	Z5	Z5	Z5	Z5	Z5	Z5	PT	PT	PT	PT	PT	PT	PT	PT	PT	PT	PT	PT	PT	PT	PT	PT	PT	PT	PT	PT	PT
		15P + 40S + 15P																																												

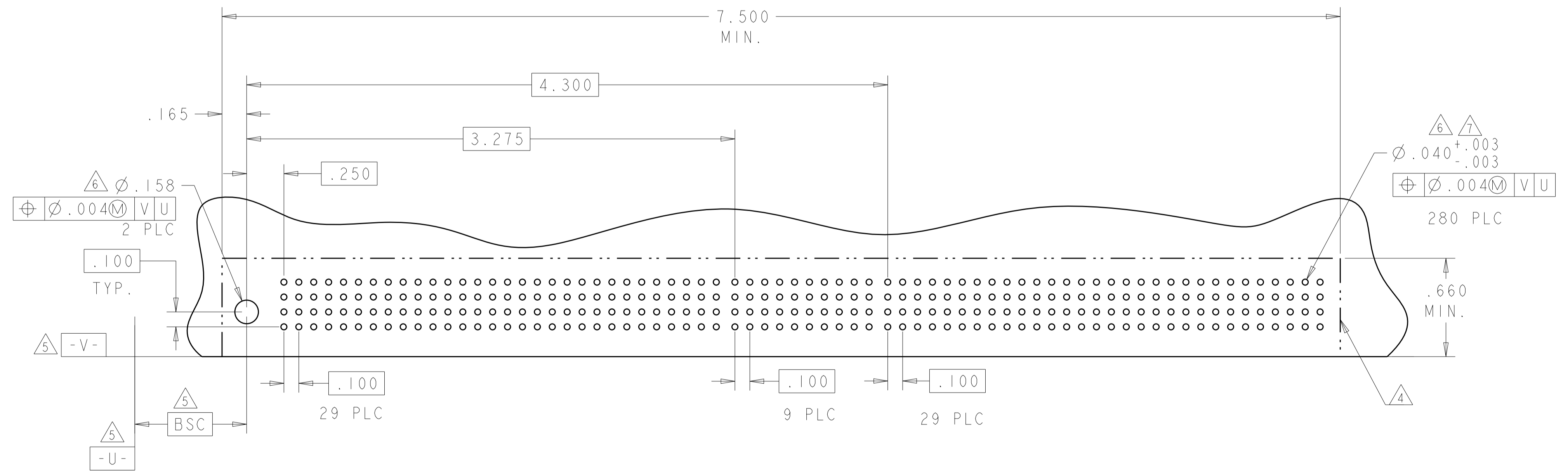

PART NUMBER	ROWS	POWER				SIGNAL				POWER			
		P1	P2	P3	P4	P1	P2	P3	P4	P1	P2	P3	P4
I-6450520-1	D C B A	PT	PT	PT	PT	Z5	Z5	Z5	Z5	PT	PT	PT	PT
		IP + 16S + 1P											

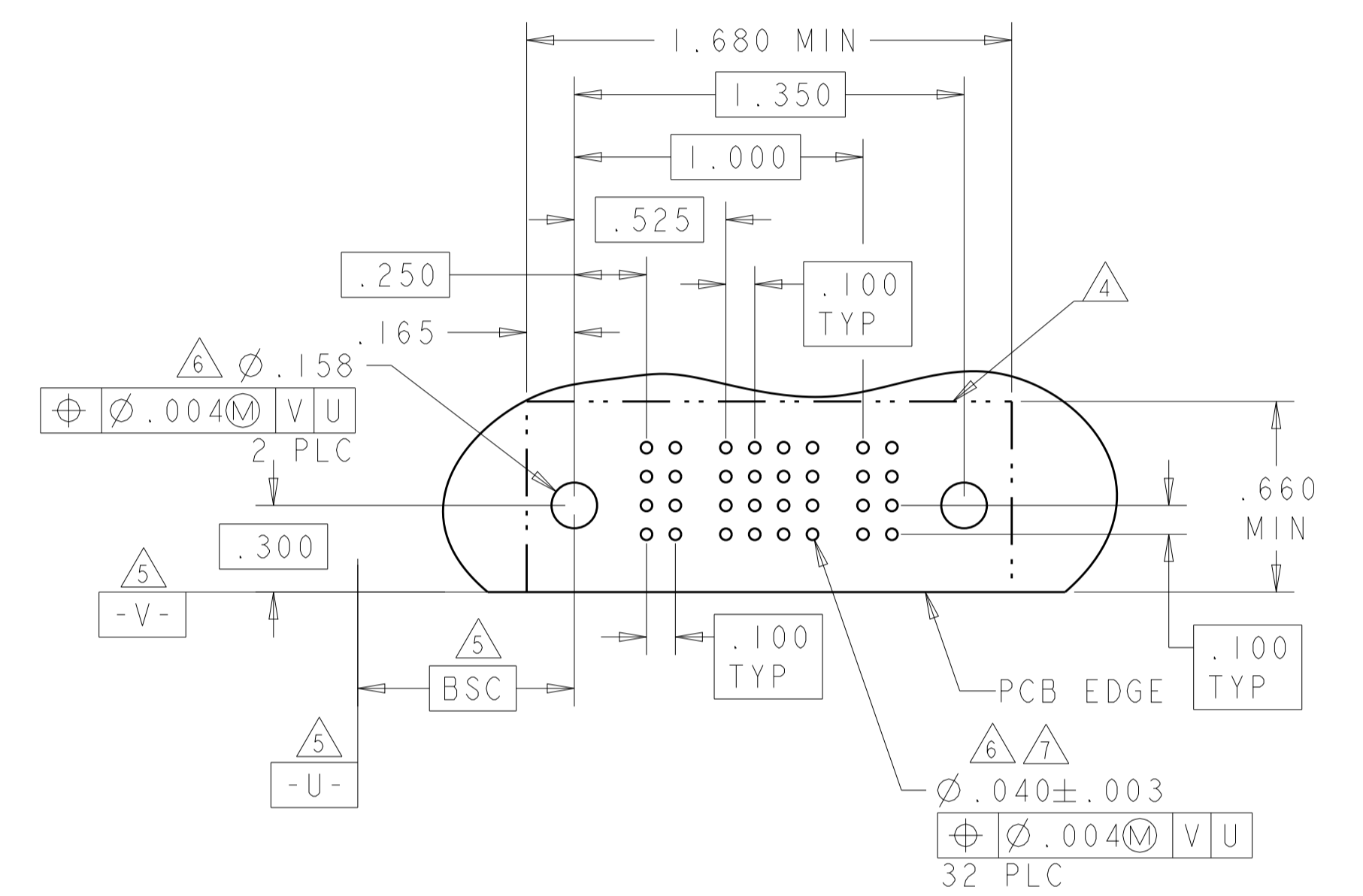

DESCRIPTION		IDENTIFIER
STD SINGAL CONTACT, .120 TAIL LENGTH ROW A		O5
STD SINGAL CONTACT, .120 TAIL LENGTH ROW B		R5
STD SINGAL CONTACT, .120 TAIL LENGTH ROW C		Y5
STD SINGAL CONTACT, .120 TAIL LENGTH ROW D		Z5
STD POWER CONTACT, .120 TAIL LENGTH		PT
HOLD DOWN		HD

THIS DRAWING IS A CONTROLLED DOCUMENT.		DWN: T. ZHANG 17MAY2006	
DIMENSIONS: INCHES		CHK: G. ZHANG 17MAY2006	
TOLERANCES UNLESS OTHERWISE SPECIFIED:		APVD: S. ZHAO 17MAY2006	
0 PLC	±.01	PRODUCT SPEC	
1 PLC	±.01	108-1973	
2 PLC	±.01	APPLICATION SPEC	
3 PLC	±.005	114-13038	
4 PLC	±.002	WEIGHT	
ANGLES	±.002	MATERIAL	
FINISH		CAGE CODE DRAWING NO	
		A100779C=6450520	
CUSTOMER DRAWING		SCALE 4:1	
		SHEET 3 OF 7	
		REV E6	

LOC	DIST	REVISIONS			
ES	00	REV	DATE	BY	APPD
		1	SEE SHEET 1		

PART NUMBER	ROWS	SIGNAL												POWER								
		P1	P2	P3	P4	P5	P6	1	2	3	4	5	6	7	8	9	P7	P8	P9	P10	P11	P12
6450520-6	D C B A	PT	PT	PT	PT	PT	PT	Z5	Z5	Z5	Z5	Z5	Z5	Z5	Z5	Z5	PT	PT	PT	PT	PT	PT
		Y5	Y5	Y5	Y5	Y5	Y5	Y5	Y5	Y5	Y5	Y5	Y5	Y5	Y5	Y5						
		R5	R5	R5	R5	R5	R5	R5	R5	R5	R5	R5	R5	R5	R5	R5						
		O5	O5	O5	O5	O5	O5	O5	O5	O5	O5	O5	O5	O5	O5	O5						
6HDP + 36S + 6HDP																						

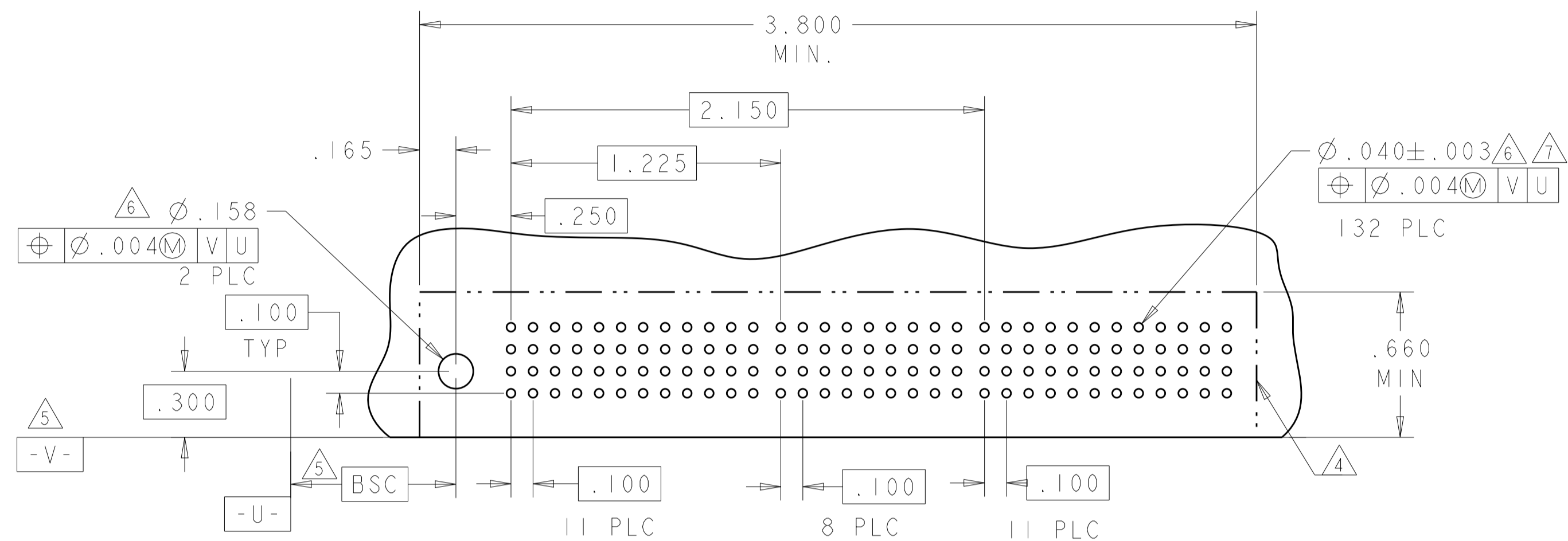

PART NUMBER	ROWS	SIGNAL												POWER									
		P1	P2	P3	P4	P5	P6	1	2	3	4	5	6	7	8	9	P7	P8	P9	P10	P11	P12	P13
6450520-7	D C B A	PT	PT	PT	PT	PT	PT	Z5	Z5	Z5	Z5	Z5	Z5	Z5	Z5	Z5	PT	PT	PT	PT	PT	PT	PT
		Y5	Y5	Y5	Y5	Y5	Y5	Y5	Y5	Y5	Y5	Y5	Y5	Y5	Y5	Y5							
		R5	R5	R5	R5	R5	R5	R5	R5	R5	R5	R5	R5	R5	R5	R5							
		O5	O5	O5	O5	O5	O5	O5	O5	O5	O5	O5	O5	O5	O5	O5							
6HDP + 36S + 7HDP																							

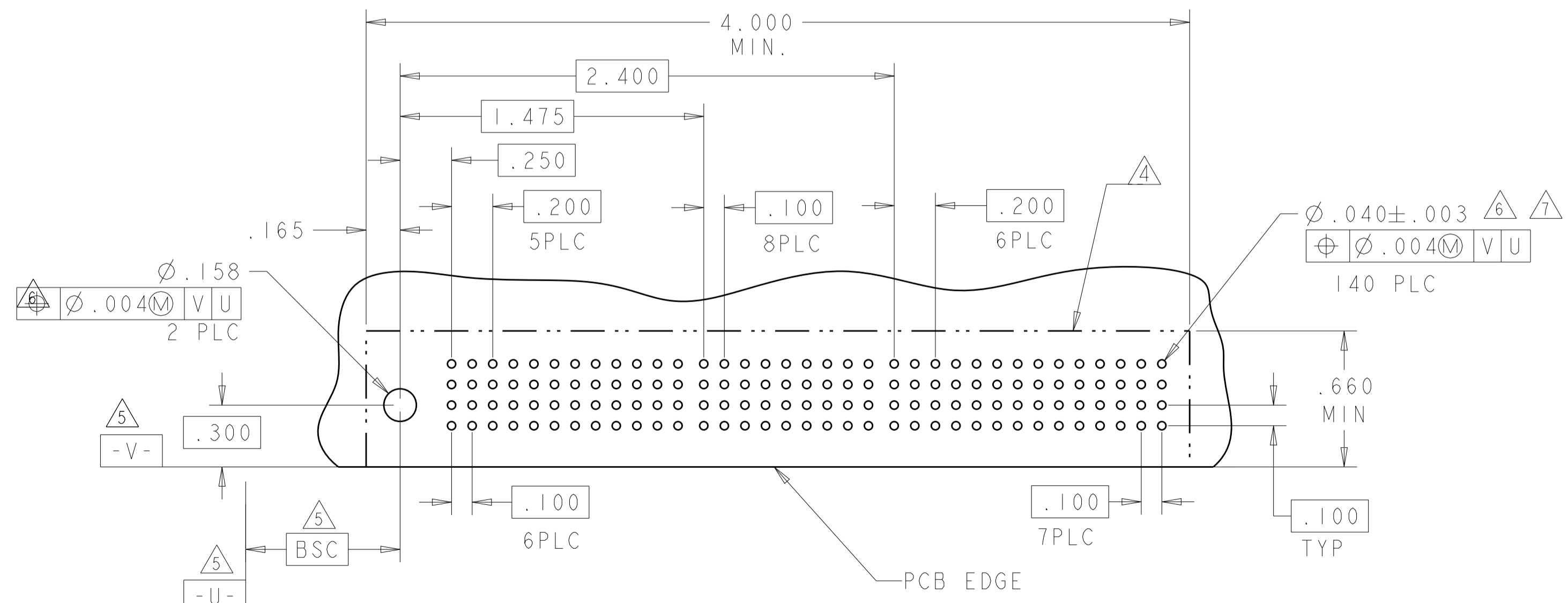

PART NUMBER	ROWS	POWER				SIGNAL				POWER			
		P1	P2	P3	P4	1	2	3	4	P5	P6	P7	P8
6450520-8	D C B A	PT	PT	PT	PT	Z5	Z5	Z5	Z5	PT	PT	PT	PT
		Y5	Y5	Y5	Y5	Y5	Y5	Y5	Y5				
		R5	R5	R5	R5	R5	R5	R5	R5				
		O5	O5	O5	O5	O5	O5	O5	O5				
IP + 8S + IP													

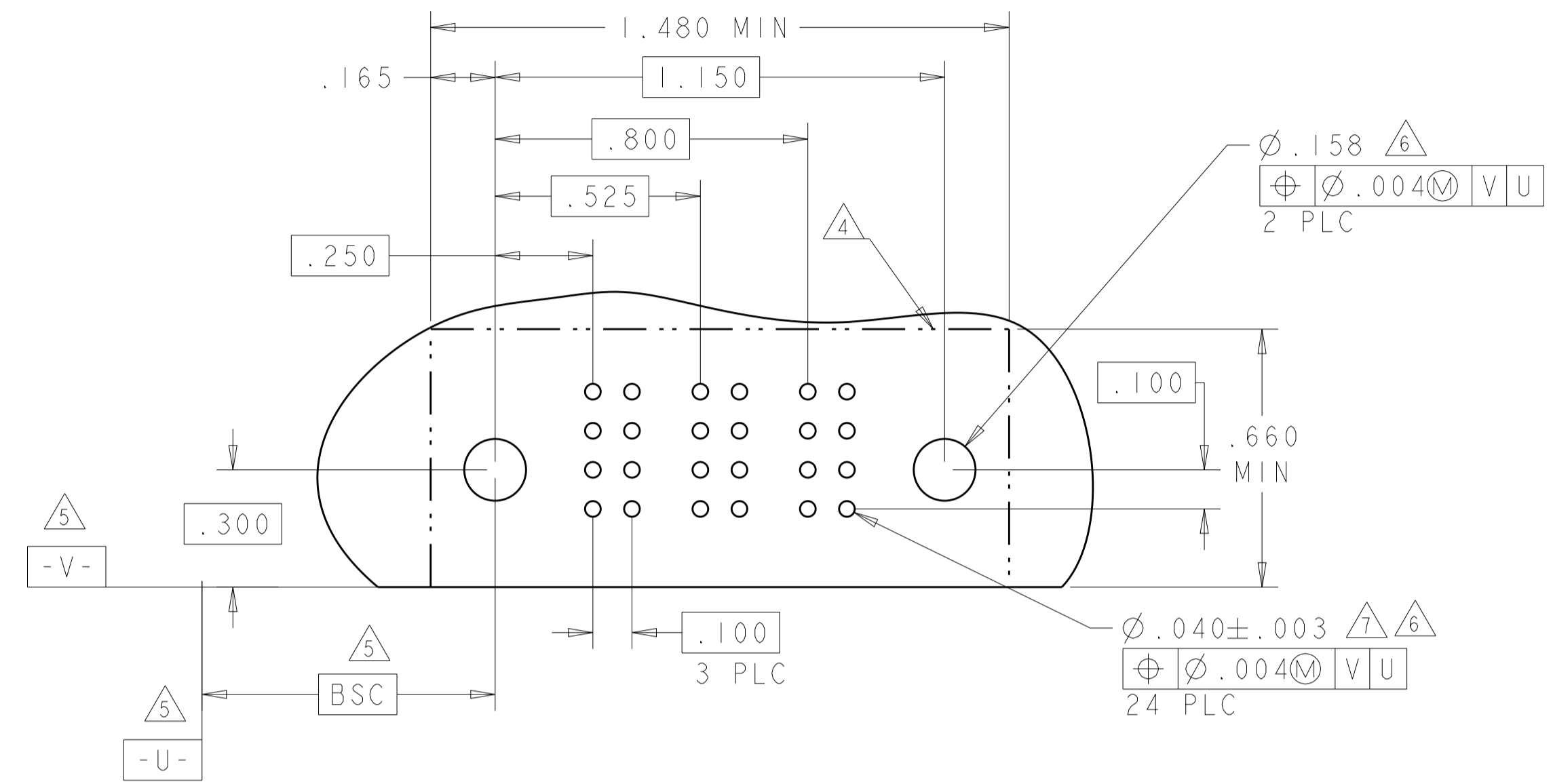

PART NUMBER	ROWS	POWER						SIGNAL						POWER							
		P1	P2	P3	P4	P5	P6	1	2	3	4	5	6	P7	P8	P9	P10	P11	P12	P13	
6450520-9	D C B A	PT	PT	PT	PT	PT	PT	Z5	Z5	Z5	Z5	Z5	Z5	PT	PT	PT	PT	PT	PT		
		Y5	Y5	Y5	Y5	Y5	Y5	Y5	Y5	Y5	Y5	Y5	Y5								
		R5	R5	R5	R5	R5	R5	R5	R5	R5	R5	R5	R5								
		O5	O5	O5	O5	O5	O5	O5	O5	O5	O5	O5	O5								
3P + 8S + 3P																					

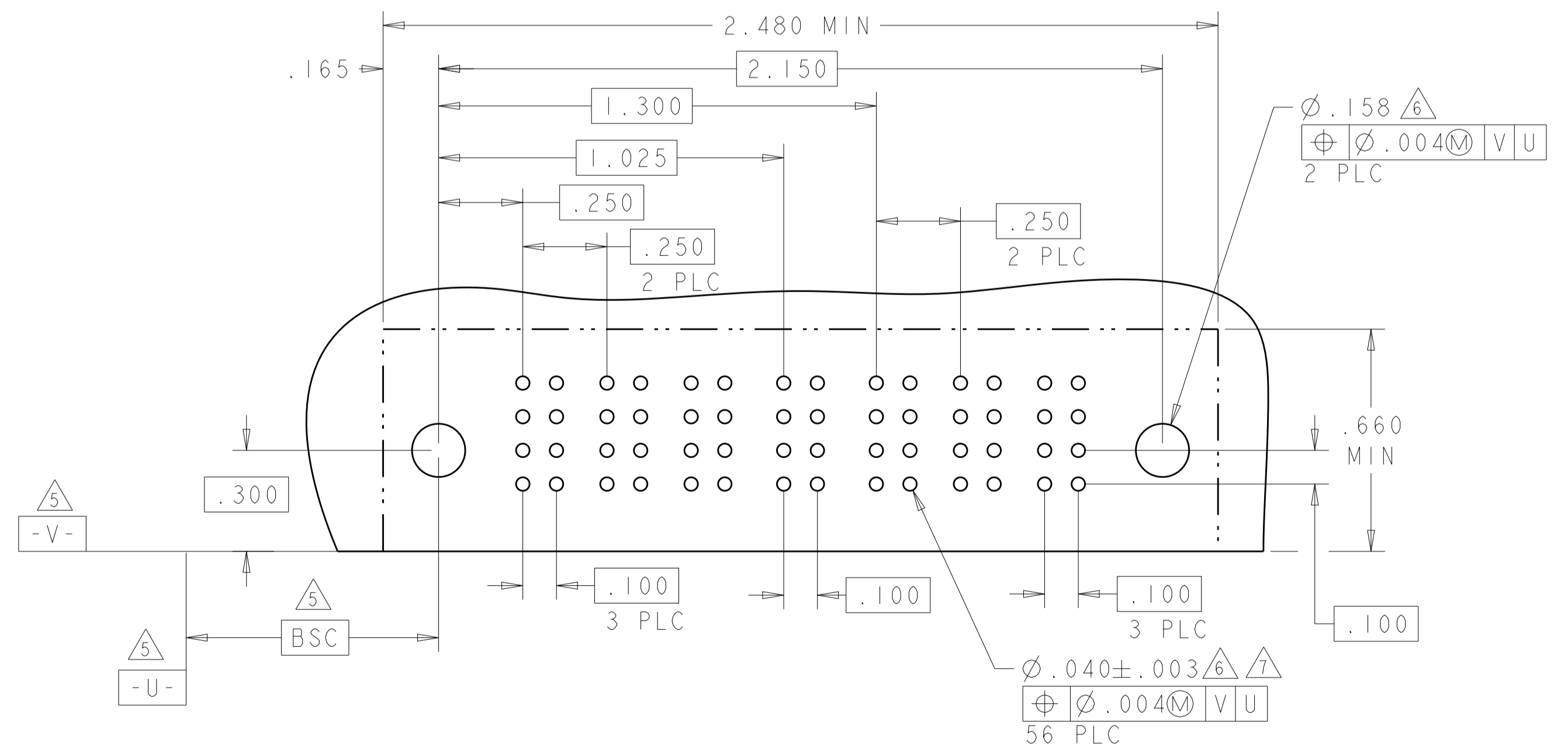

THIS DRAWING IS A CONTROLLED DOCUMENT.

DIMENSIONS: INCHES 	TOLERANCES UNLESS OTHERWISE SPECIFIED: 0 PLC ±. 1 PLC ±.01 5 PLC ±.005 4 PLC ±.0020 ANGLES ±.020	DWN: T. ZHANG 17MAY2006 CHK: G. ZHANG 17MAY2006 APVD: S. ZHAO 17MAY2006 PRODUCT SPEC 108-1973 APPLICATION SPEC 114-13038 WEIGHT CUSTOMER DRAWING	NAME: RIGHT ANGLE HEADER ASSEMBLY W/ GUIDE, PRESS FIT MULTI-BEAM XL SIZE: A1 CAGE CODE: 100779 DRAWING NO: 6450520 SCALE: 4:1 SHEET: 4 OF 7 REV: E6
---------------------------	---	--	---

TE Connectivity

LOC	DIST	REVISIONS			
P	LTN	DESCRIPTION	DATE	DMN	APVD
-	-	SEE SHEET 1	-	-	-

PART NUMBER	ROWS	POWER									SIGNAL						POWER										
		P1	P2	P3	P4	P5	P6	P7	P8	P9	P10	1	2	3	4	5	6	P11	P12	P13	P14	P15	P16	P17	P18	P19	P20
I-6450520-2	D C B A	PT	PT	PT	PT	PT	PT	PT	PT	PT	PT	Z5	Z5	Z5	Z5	Z5	Z5	PT	PT	PT	PT	PT	PT	PT	PT	PT	PT
		Y5	Y5	Y5	Y5	Y5	Y5	Y5	Y5	Y5	Y5	R5	R5	R5	R5	R5	R5										
		O5	O5	O5	O5	O5	O5	O5	O5	O5	O5																
10P + 24S + 10P																											

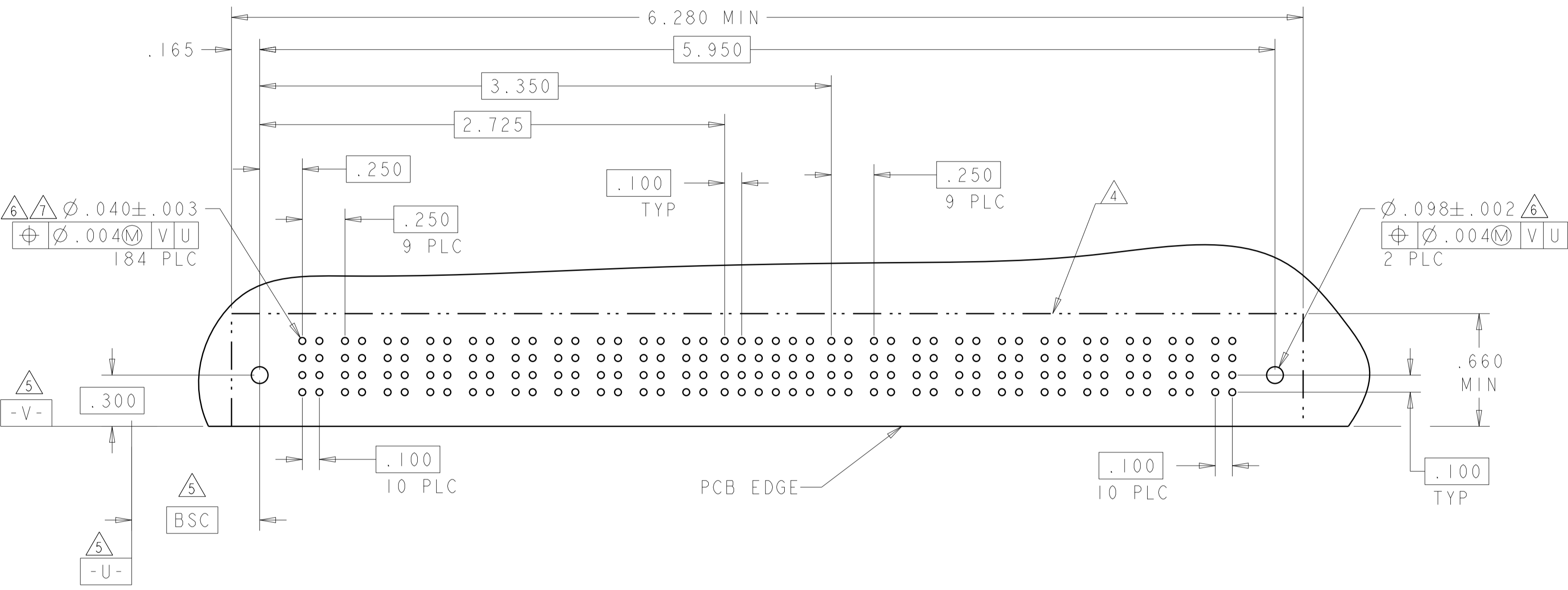

PART NUMBER	ROWS	SIGNAL															
		1	2	3	4	5	6	7	8	9	10	11	12	13	14	15	16
I-6450520-3	D C B A	Z5	Z5	Z5	Z5	Z5	Z5	Z5	Z5	Z5	Z5	Z5	Z5	Z5	Z5	Z5	Z5
		Y5	Y5	Y5	Y5	Y5	Y5	Y5	Y5	Y5	Y5	Y5	Y5	Y5	Y5	Y5	Y5
		R5	R5	R5	R5	R5	R5	R5	R5	R5	R5	R5	R5	R5	R5	R5	R5
64S																	

PART NUMBER	ROWS	SIGNAL											
		1	2	3	4	5	6	7	8	9	10	11	12
I-6450520-4	D C B A	Z5	Z5	Z5	Z5	Z5	Z5	Z5	Z5	Z5	Z5	Z5	Z5
		Y5	Y5	Y5	Y5	Y5	Y5	Y5	Y5	Y5	Y5	Y5	Y5
		R5	R5	R5	R5	R5	R5	R5	R5	R5	R5	R5	R5
48S													

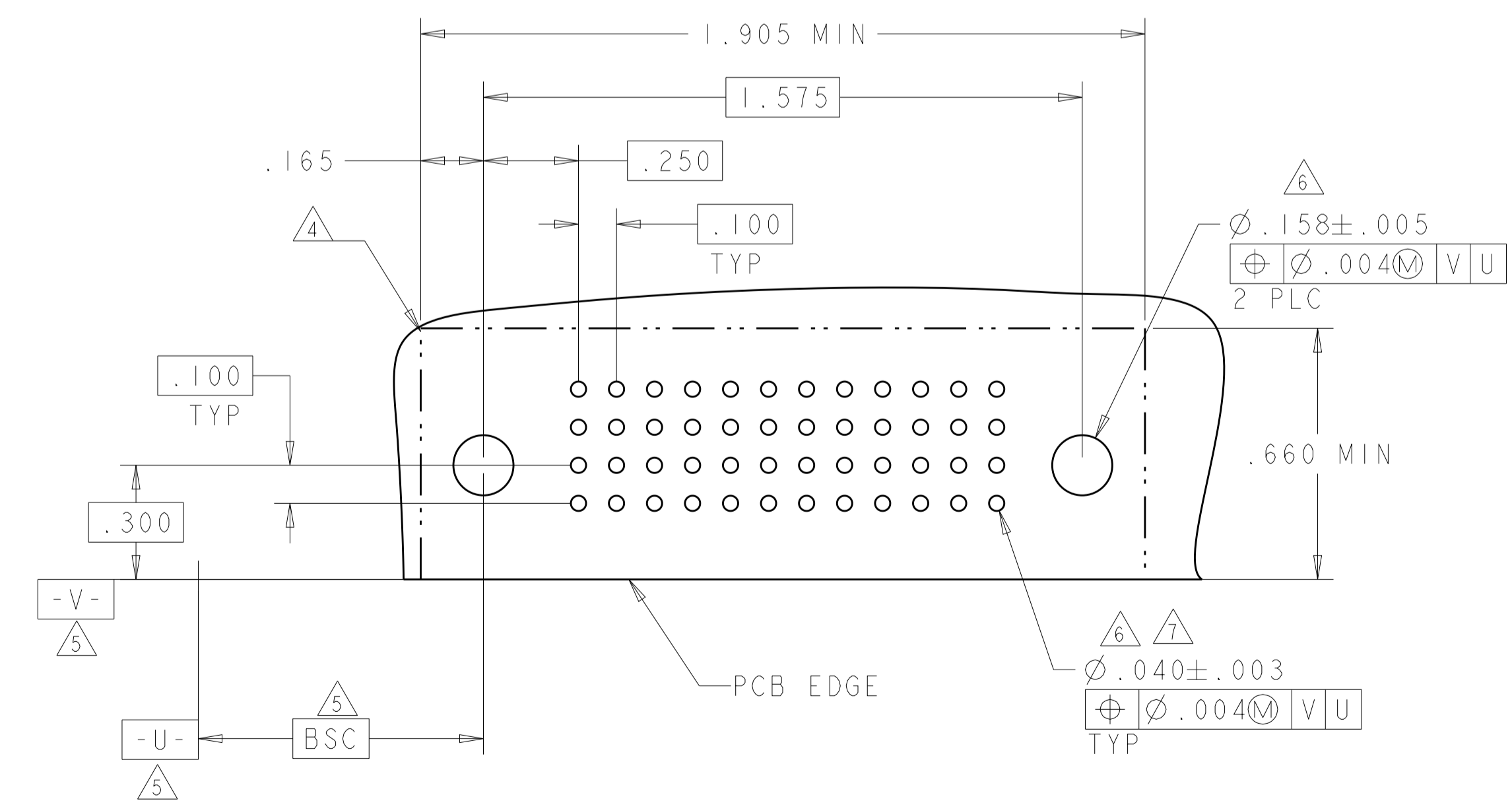
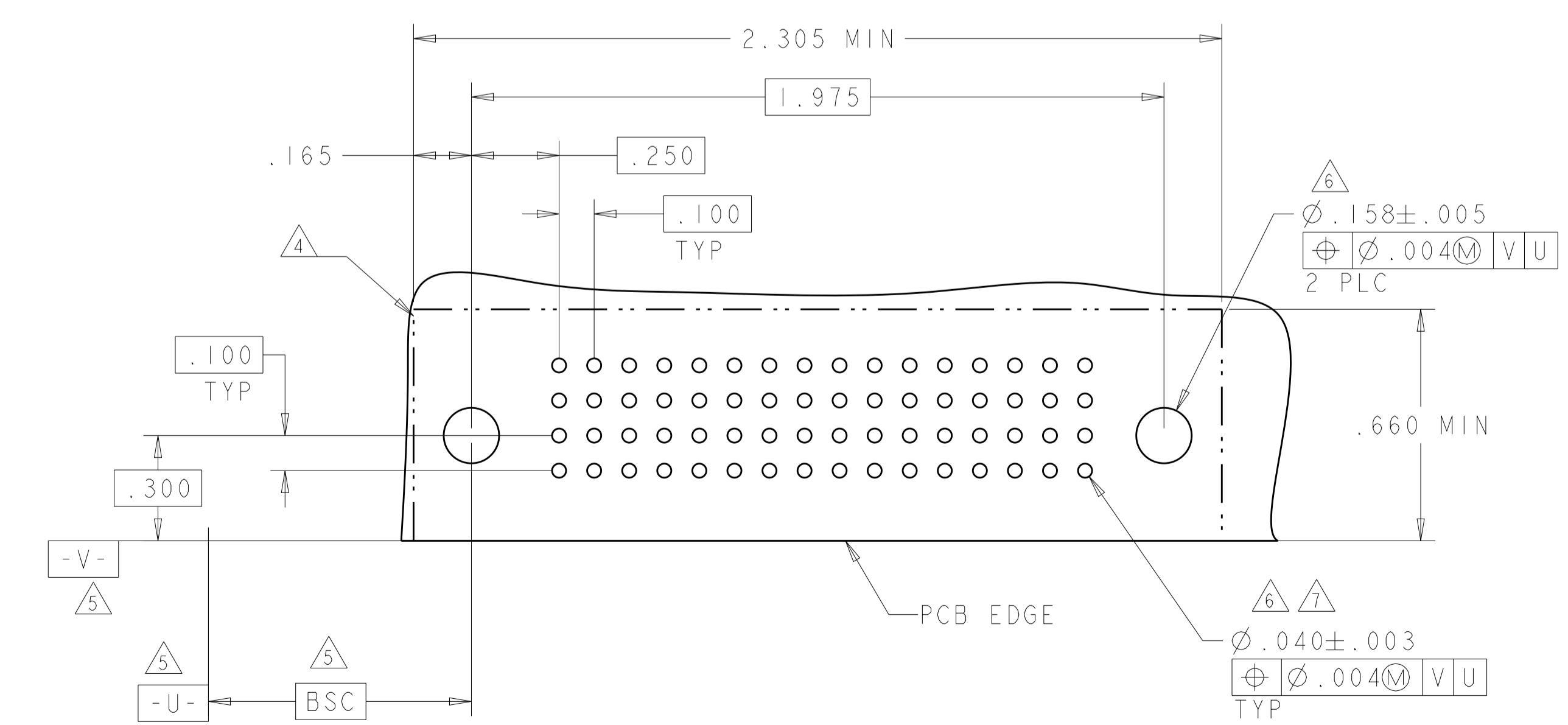

THIS DRAWING IS A CONTROLLED DOCUMENT.

DMN: T. ZHANG	17MAY2006		TE Connectivity RIGHT ANGLE HEADER ASSEMBLY W/ GUIDE, PRESS FIT MULTI-BEAM XL
CHK: G. ZHANG	17MAY2006		
APPV: S. ZHAO	17MAY2006		
NAME: PRODUCT SPEC			
DIMENSIONS: INCHES		APPLICATION SPEC	
TOLERANCES UNLESS OTHERWISE SPECIFIED:		RESTRICTED TO	
0 PLC ± .01	1 PLC ± .01	SIZE: CAGE CODE DRAWING NO	
2 PLC ± .01	3 PLC ± .005	A100779C=6450520	
4 PLC ± .0020	ANGLES ± .0020	WEIGHT	
MATERIAL FINISH		CUSTOMER DRAWING	
		SCALE: 4:1 SHEET 5 OF 7 REV: E6	

LOC	DIST	REVISIONS			
ES	00	REV	DATE	BY	APPV
		-	SEE SHEET 1	-	-

PART NUMBER	ROWS	POWER			SIGNAL			
		P1	P2	P3	1	2	3	4
		PT	PT	PT	Z5	Z5	Z5	Z5
1-6450520-5	D C B A				Y5	Y5	Y5	Y5
					R5	R5	R5	R5
					O5	O5	O5	O5

3ACP + 16S

PART NUMBER	ROWS	POWER				SIGNAL						POWER			
		P1	P2	P3	P4	1	2	3	4	5	6	P5	P6	P7	P8
		PT	PT	PT	PT	Z5	Z5	Z5	Z5	Z5	Z5	Z5	PT	PT	PT
1-6450520-6	D C B A					Y5	Y5	Y5	Y5	Y5	Y5				
						R5	R5	R5	R5	R5	R5				
						O5	O5	O5	O5	O5	O5				

4P + 24S + 4P

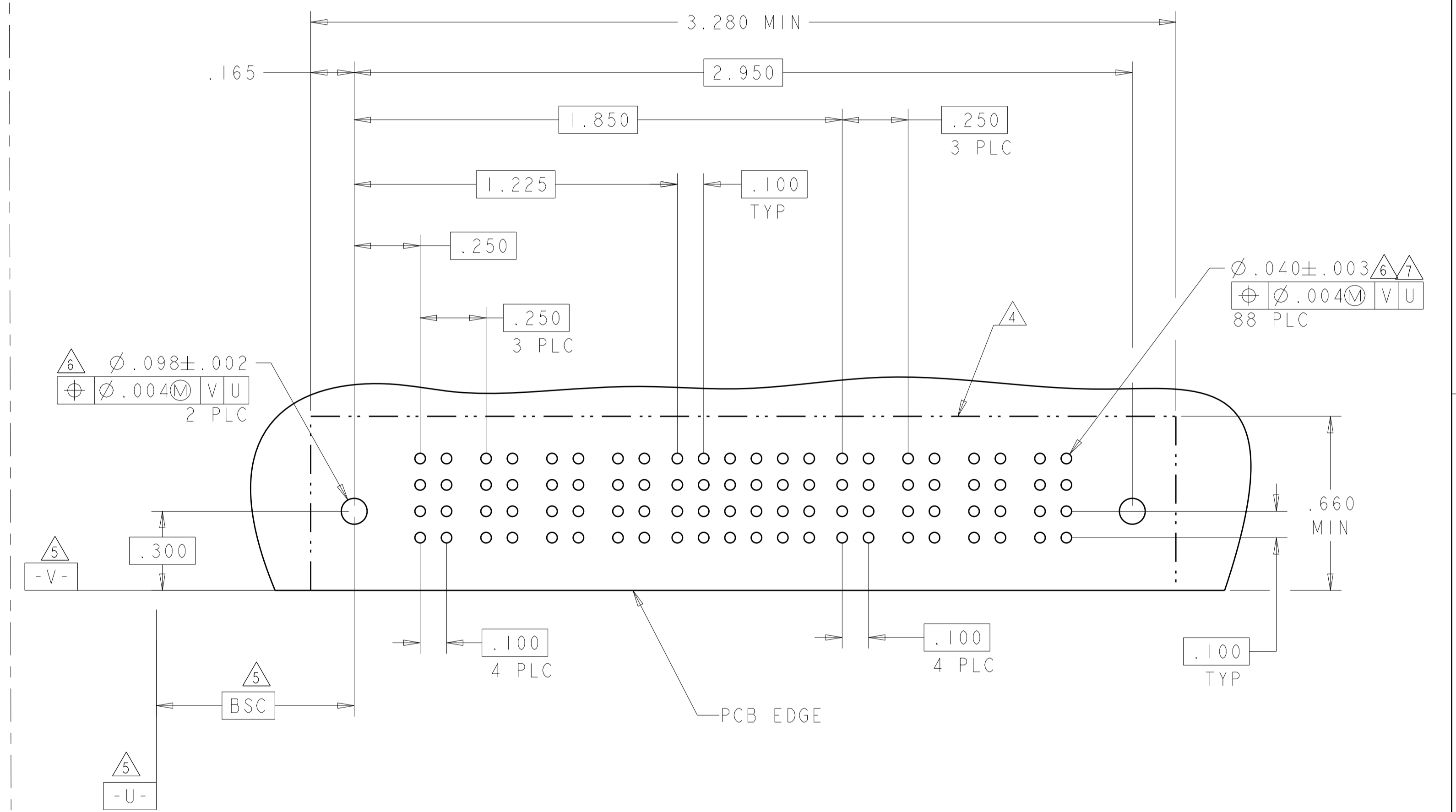
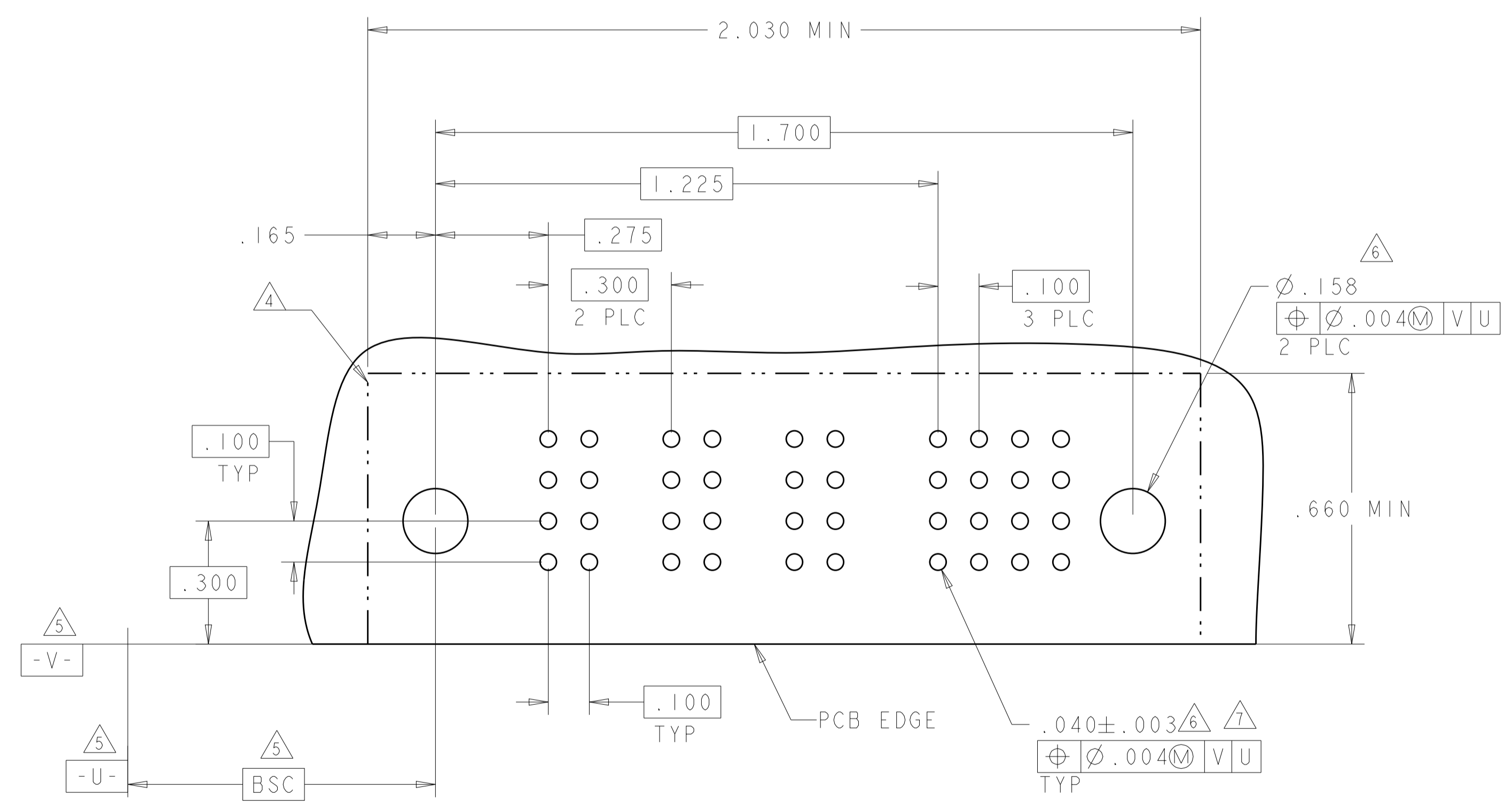

THIS DRAWING IS A CONTROLLED DOCUMENT.

DIMENSIONS: INCHES	TOLERANCES UNLESS OTHERWISE SPECIFIED: 0 PLC ±. 1 PLC ±.01 2 PLC ±.01 3 PLC ±.005 4 PLC ±.0020 ANGLES ±.2°	OWN: T. ZHANG 17MAY2006 CHK: G. ZHANG 17MAY2006 APPV: S. ZHAO 17MAY2006	NAME: RIGHT ANGLE HEADER ASSEMBLY W/ GUIDE, PRESS FIT MULTI-BEAM XL
MATERIAL:	FINISH:	PRODUCT SPEC: 108-1973 APPLICATION SPEC: 114-13038 WEIGHT:	SIZE: A100779 CAGE CODE: C=6450520 RESTRICTED TO:
CUSTOMER DRAWING		SCALE: 4:1	SHEET 6 OF 7 REV: E6

TE Connectivity

LOC	DIST	REV	DATE	BY	APPD
ES	00				
REVISIONS			DESCRIPTION	DATE	BY
			SEE SHEET 1		

PART NUMBER	ROWS	POWER				SIGNAL				POWER				
		P1	P2	P3	P4	1	2	3	4	P5	P6	P7	P8	P9
E6 1-6450520-7	D C B A	PT	PT	PT	PT	Z5	Z5			PT	PT	PT	PT	PT
						Y5	Y5							
						R5	R5							
						O5	O5							
4P + 16S + 5P														

PART NUMBER	ROWS	POWER				SIGNAL		POWER					
		P1	P2	P3	P4	1	2	P5	P6	P7	P8	P9	P10
E6 1-6450520-8	D C B A	PT	PT	PT	PT	Z5	Z5	PT	PT	PT	PT	PT	PT
						Y5	Y5						
						R5	R5						
						O5	O5						
4P + 8S + 6P													

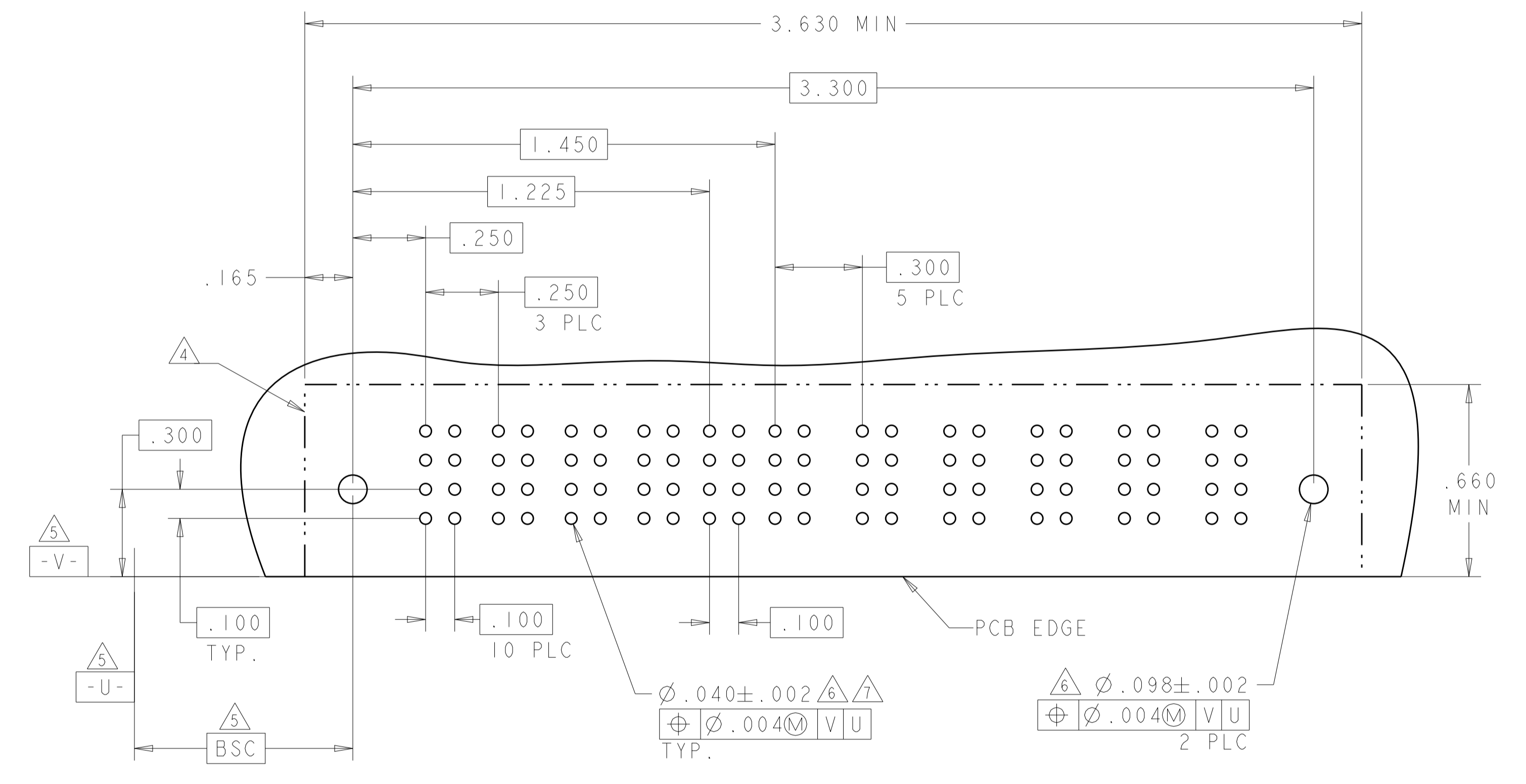
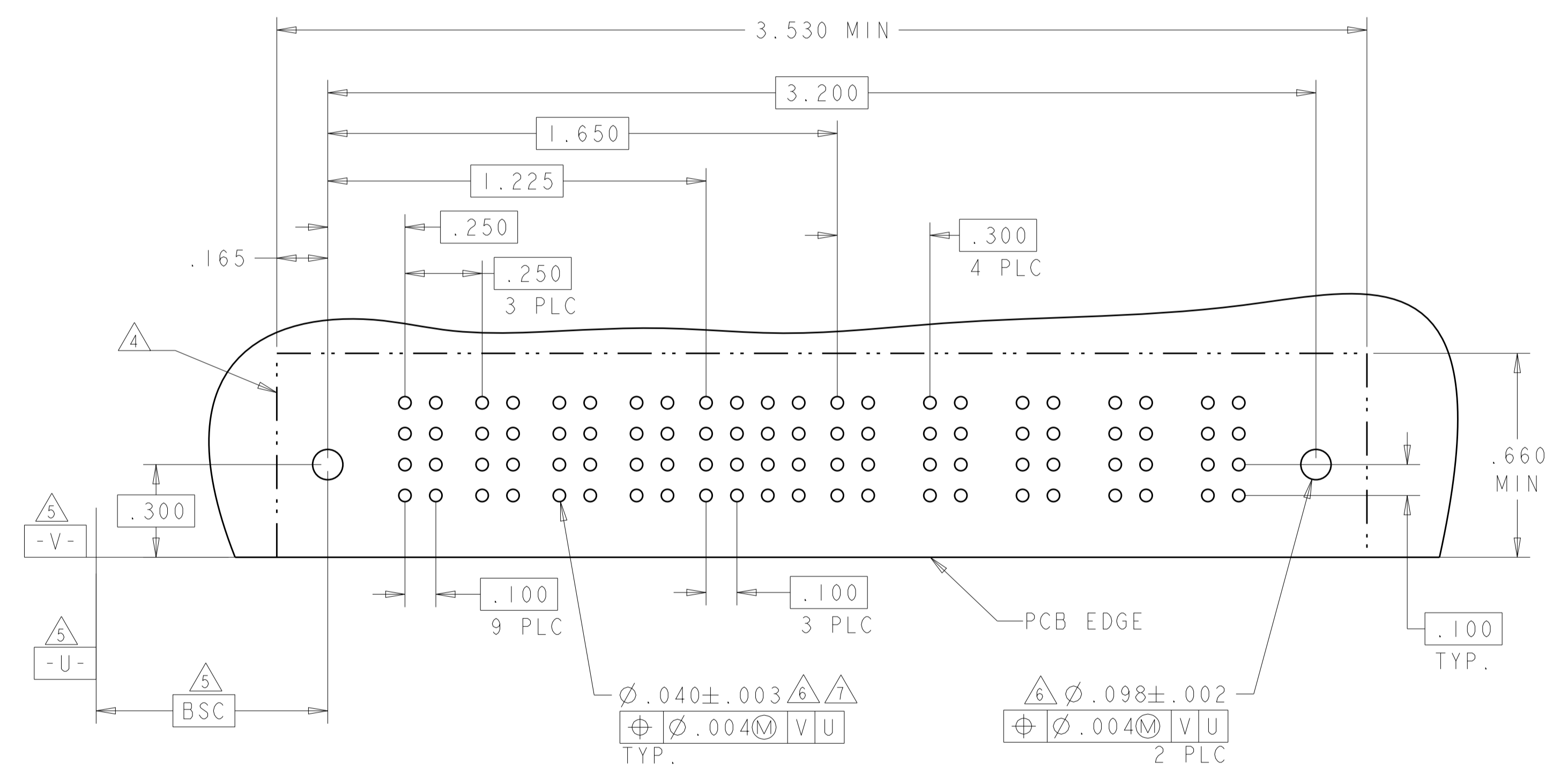

THIS DRAWING IS A CONTROLLED DOCUMENT.		OWN T. ZHANG	17MAY2006	STE TE Connectivity
DIMENSIONS: INCHES		CHK G. ZHANG	17MAY2006	
TOLERANCES UNLESS OTHERWISE SPECIFIED:		APVD S. ZHAO	17MAY2006	NAME RIGHT ANGLE HEADER ASSEMBLY W/ GUIDE, PRESS FIT MULTI-BEAM XL
0 PLC ±		PRODUCT SPEC		SIZE 108-1973
1 PLC ±.01		APPLICATION SPEC		RESTRICTED TO
2 PLC ±.005		WEIGHT		A100779C=6450520
3 PLC ±.0020		SCALE		4:1
4 PLC ±.0020		SHEET		7 OF 7
ANGLES		REV		E6
FINISH		CUSTOMER DRAWING		